

Assembly and Operating Instructions

.bock^{///}

livorno

Content

Dear Customer,

In deciding to buy a therapy and rehabilitation bed from Bock you have opted for a care product that has a long service life and delivers first class functionality at the highest safety level. Our electrically adjustable care beds guarantee optimum comfort when lying, and support professional care activities. The focus is on people who need care, encouragement and protection. We have created the basic requirements for this with our care products. We urge you to prevent potential malfunction and risk of accidents by complying strictly with the safety and operating instructions and carrying out the necessary maintenance.

Yours sincerely



Klaus Bock

4	1. General information
	1.1 Practical – no packaging
	1.2 First impression – visual inspection
6	2. Cleaning, care and disinfection
	2.1 Cleaning and care
	2.2 Disinfection
	2.3 Avoiding danger
8	3. General description of function
	3.1. Structure and function
	3.2 How to assemble fast and easily:
	3.3 Caution: Risk of injury
17	4. Electric components
	4.1 Drive unit
	4.2 Control box for all functions
	4.3 Height adjustment drive unit
	4.4 Lockable hand control, single fault safety
	4.5 Caution: Electrical drive unit
21	5. Drive units
	5.1 IlcoFlexx 581 drive systems
	5.2 Mains isolation
23	6. Accessories
	6.1 Special sizes
	6.2. Assembling bed extensions
	6.3 Assembling accessories
	6.4 Mattresses
	6.5 Special mattress ripocare
29	7. Setting up and operating – livorno
	7.1 Design and purpose
	7.2 Special features
	7.3 livorno in parts
	7.4 The livorno ready for use
	7.5 Control
	7.6 Disassembly
	7.7 Relocation
	7.8 Transport and storage conditions
	7.9 Functioning advice
	7.10 Disposal
	7.11 Troubleshooting
40	8. Safety guidelines
	8.1 Safety guidelines for electrically operated bed systems
	8.2 The “Top-Ten” safety guarantees.
	8.3 Technical safety checks with service

*** Warning note from Bock**

As the user, you should read these installation and operating instructions completely in order to avoid any damage or malfunction in the course of assembly and use.

1. General information

The various bed systems that are made by Hermann Bock GmbH meet the special requirements for use in rehabilitation and therapy establishments as well as for care at home. Their reliable functioning and long service life mean that all our beds are of a particularly high quality. Our beds need little maintenance when used and inspected properly. No bed leaves the Hermann Bock production plant until it has passed final quality inspections and has been tested by a technical inspectorate in Germany named TÜV. Every health bed thus meets the requirements of directive 93/42/EEC for medical products. The beds are tested not only on the basis of the new European standard EN 1970 but also on the basis of EN 60601-2-38 – the standard for electric medical equipment with special specifications for the safety of electrically operated hospital beds.

The electric components of our beds conform with safety standard EN 60601-1 for medical devices.

All care beds are subjected to a careful function check on site by our trained delivery staff. At the same time authorised persons are given basic training in the functioning and safe handling of the beds. Additional information is given in the Bock security guide, these assembly and operating instructions and in the "Upgrading with Bock" brochure.

Note: An evaluation of the bed in accordance with EN 60601-1 is only partly possible, since for beds there is the product specific standards EN 60601-2-38+A1. Should there be product specific standards, these should be used in the first place for testing. EN 60601-1 is used additionally for electronic testing.

1.1 Practical – no packaging

Bock has developed a special system that enables our care beds to be transported reliably and stored in a space-saving way. The intelligent Bock plug-in system is very environmentally-friendly because it comes with minimal any packaging material. Furthermore, the bed can be assembled easily and quickly by one person. Bed models that require more extensive assembly work are put together completely on Bock's premises and shipped without packaging.

1.2 First impression – visual inspection

Before assembling the bed and putting it into service, look at it carefully to see that it is complete and has no visible damage. Only when you are convinced that the bed is in its proper, fault-free state should you get round to learning the correct way of using the individual bed elements in the following function description.

> Tip from Bock

Please refer to the assembly instructions for your specific model (from chapter 7 on) to see which parts, and how many of them, have to be present for your visual checks of the care bed.

Explanation of symbols used on name plate:

 Mark of conformity according to guidelines for medical products

IPX4 Protection of electrical parts from splashwater



„Medical equipment part, type B“



„Only to be used in dry environment“



Protection class II (double insulation, protective insulation)



This product must be disposed to a selected waste disposal within the European Union. This product may not be disposed together with unsorted domestic waste.



Take note of the accompanying documents

> Tip from Bock

Scratches that go through the entire coating should be sealed with suitable repair agents to prevent the penetration of moisture.

2. Cleaning, care and disinfection

The individual bed elements are made of first-class materials, largely from steel, whose surface has been given a durable polyester powder coating.

The surfaces of all wooden parts have been sealed with a material that contains no harmful substances. The patented ripolux support system is made of high-grade plastic. All bed elements can be easily cleaned and looked after with wipe-and-spray disinfectants that meet the hygiene requirements for the various areas of use. The usefulness and optical condition of your care bed will be retained for a long time if you heed the following care instructions.

2.1 Cleaning and care

Steel tubing and sprayed metal parts:

To clean and care for these surfaces use a moist cloth with a mild commercial household cleanser.

Wooden, decorative and plastic parts:

All common furniture care and cleansing agents are suitable. To clean plastic parts a moist cloth with a mild commercial household cleaner is suitable. A special product for plastic material should be used for the care of plastic surfaces.

Motor unit:

The motor housing should only be wiped with a slightly moist cloth in order to prevent moisture getting into it.

Lying surface systems ripolux und ripoplan:

To clean the plastic carrier and spring elements as well as the base use a slightly moistened cloth without adding any cleaner, or add a product that has been designed specifically for plastics. If the support system needs particularly intensive cleaning, remove the spring elements from the carrier elements by turning them 90° to the left and pulling the carrier elements from the lying surface frame, which takes a few minutes. The plastic elements that you have removed in this way can be cleaned or sprayed with hot flowing water. The plastic elements can be sprayed with a suitable plastic cleaning agent for disinfection. Most of the moisture can be removed from the surface of the plastic by a gentle shaking, the remainder will dry within a short time. After drying thoroughly with no residue, re-assemble the parts.

Alternatively the individual lying surface elements can be completely removed from the frame and cleaned (see chapter 3.1 and 3.2).

Hygiene certificate:

ripolux fulfils all requirements that are set out for a product after suitable cleaning with listed products in accordance with the currently valid German Society for Hygiene and Microbiology (DGHM) list and according to the Robert-Koch-Institute (RKI-guidelines) "Hygiene Requirements for the Treatment of Medical Products", the recommendations for infection protection, and was therefore certified.

2.2 Disinfection

All disinfectants set out in EN 12720 can be wiped on the beds to clean them. To maintain the material condition of plastic elements such as the motor housing, ripolux and ripoplan, only use mild agents. Concentrated acids, aromatic and chlorinated hydrocarbons, high alcohol, ether, ester and ketone corrode the material and should therefore not be used.

2.3 Avoiding danger

Before cleaning and disinfecting electric parts of your care beds it is essential to read the following rules in order to avoid danger in conjunction with cleaning and disinfecting them. Failure to comply with these rules can result in personal injury and considerable damage to the electric cabling and the drive unit.

1. Pull the mains plug out and place it where it cannot come into contact with excess water or cleaning agents.
2. Check that all plug-in connections fit properly.
3. Check the cabling and electric parts for damage. If you detect any damage do not clean the parts involved but first make sure that the defect is eliminated by the operator or by authorised technicians.
4. Before putting the bed back into service check that the mains plug does not have any residual moisture on it, and rub or blow it dry if necessary.
5. If you suspect that moisture may have penetrated any electric components pull out the mains plug immediately, or do not reconnect it to the mains if you have already removed it. Take the bed out of service without delay, label it accordingly, and notify the operator.

* Warning note from Bock

Never use scouring agents or other abrasive cleaners, cleaning pads or stainless-steel care agents to clean the beds. Nor should you use organic solutions such as halogenated/aromatic hydrocarbons and ketones, or acidic and alkaline cleaners.

The bed must never be sprayed with a water hose or high-pressure cleaner because this could let moisture penetrate the electric components, thus leading to malfunctions and danger.

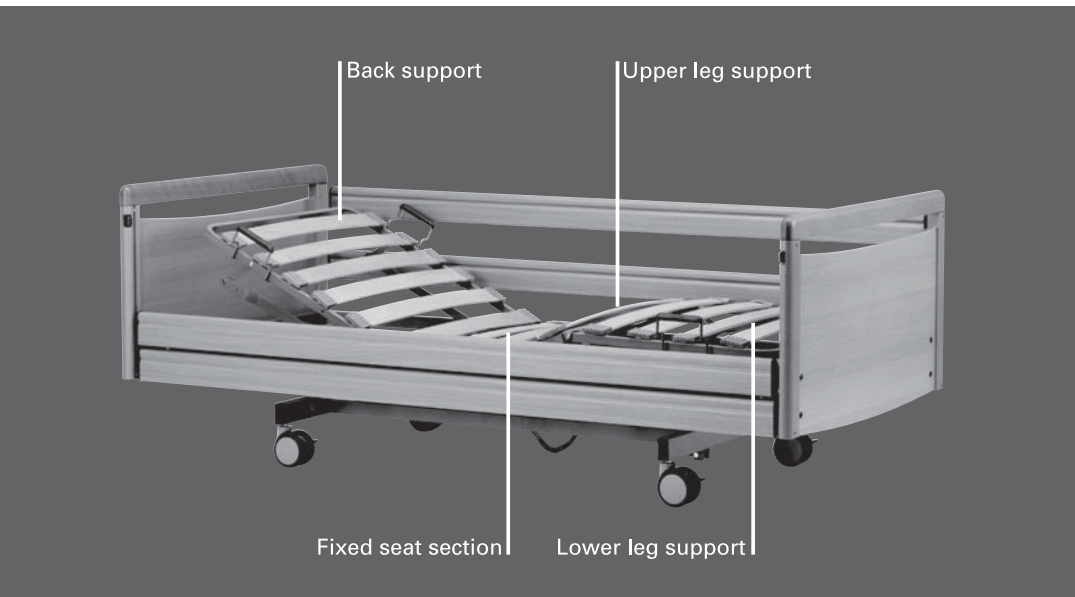

3. General description of function

3.1. Structure and function

Lying surface

All Bock care beds can be equipped with two different lying surface versions as an option to the a stable slatted frame:

The patented ripolux anti-decubitus system

The patented ripolux support system is available for any lying surface. ripolux consists of a comprehensive tubular steel lying surface frame with four lying sections: Back support, fixed seat section, upper leg support and lower leg support. On the lying surface frames there are four ripolux carrier elements made of high-grade plastic with a total of 51 spiroplex spring elements. The electrical adjustment of ripolux is performed without limitation in the same manner regardless of the Bock bed model.

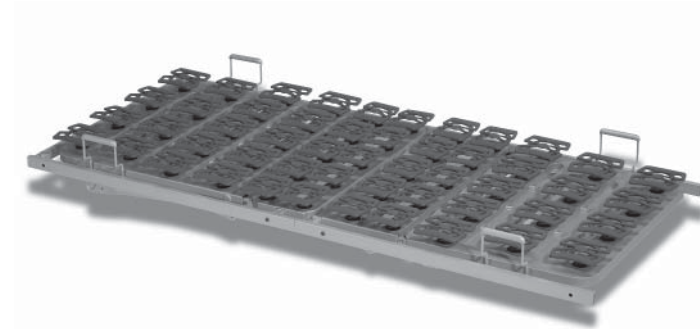

The ripolux support system includes the following:

- 4 plastic carrier elements
- 51 plastic spring elements
- 51 rubber connecting pieces for the spring elements

3.2 How to assemble fast and easily:

1. Place the carrier elements with the pre-assembled Spiroplex spring elements on the cross-rails of the lying surface frame in such a way that the Velcro patches lie exactly on top of each other, and press the elements firmly together.
2. If necessary press the spring elements firmly into the rubber connection points.

Do the following if you need to remount individual spring elements after disassembly, for example after cleaning or replacement:

Place the Spiroplex spring elements individually on the carrier elements one after another. For that simply place every spring element (A) with its rubber connection piece (B) into the designated fixing hole and fix it there with a light push. Make shure that all elements are aligned in exactly the same way and straight.

To disassemble the spring elements jerk them off of the lying surface.



The ripoplan plastic base system

The four plastic base elements can be easily fitted onto the same carrier system as ripolux. The ripoplan lying surface is just as functional as a slatted frame and offers additional advantages when cleaning.

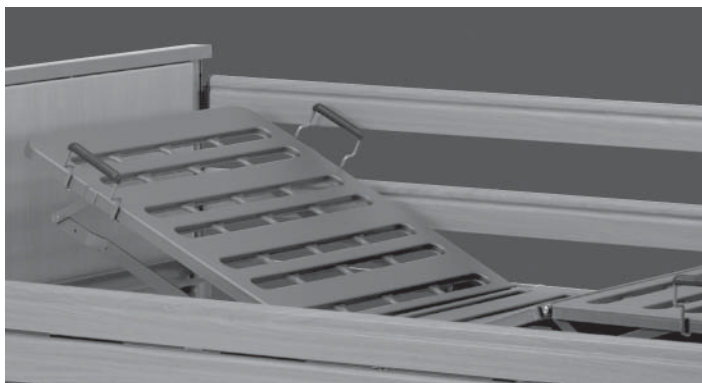

The ripoplan support system

Functional areas

The functional areas of all four versions are identical and are spread over four areas:

Back support, fixed seat section, upper leg support and lower leg support.

The frame for the lying surface is made of welded steel tubing that has been covered with a PE powder coating.

The height of the lying surface is continuously adjustable by means of 24 V direct current motors that are operated via the easy-to-use hand control. The back support is electrically adjustable from 0 to 70 degrees. The electrical adjustment of the ripolux lying surface and ripoplan plastic base system is performed without limitations in the same manner regardless of the bed model.

The leg section

The leg section consists of a two-part foot unit. Each individual position can be continuously adjusted by pressing a button on the hand control. The electronic hand control can also be used for an automatic tri-function to raise the occupant's legs to a stretched position and to make a bend in the area between the heart and knees. The lower leg support automatically moves parallel to the lying surface in proportion to the upper leg support. The leg section can be lowered with the aid of a 9-volt battery in the event of a power failure.

The chassis

The telescopic lifting chassis consists of a basic frame whose height is adjusted by two lifting columns. The surface of this steel tubing construction has a heat seated PE powder coating.

The splitted siderails

The care bed livorno is optionally available with splitted side rails.

The splitted side rails are designed to protect the patients from falling out of the bed and enable a safe and comfortable entrance and exit to the bed. The side rails can be set into the raised or lowered position through a joint on the inner side of the side rails. The side rails can only be lowered from the raised position from outside of the bed via a special locking mechanism.

Usage of the splitted siderails

The locking mechanism of the splitted side rails can be found behind the metal blend, which can be seen underneath the wooden side rail.

If the splitted side rails should be lowered, every single element must be unlocked by its locking mechanism.

Therefore grab the upper edge of the side rail with one hand. Move the other hand underneath the metal rail beneath the wooden side rail and grab the movable grip rail (Fig. 1). The grip rail is covered with a rubber border. Now press the movable grip rail in order to loose the locking mechanism of the side rail (Fig. 2).

When the locking mechanism is unlocked, take the hand off the movable grip rail and lower the side rail by moving it slightly to the front and downwards (Fig. 3). Take care that you pull out the hand, which unlocked the locking mechanism, before you lower the side rail, because it could be squeezed by the wooden side rail!

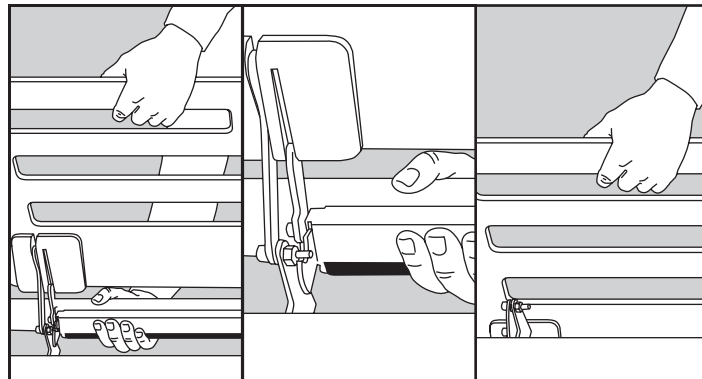

Left: fig. 1, center: fig. 2, right: fig. 3

When the splitted side rail should be raised into the upper position, grab the wooden side rail at the upper side and lift it as high as possible, until the locking mechanism locks audibly.

The splitted side rails can be joined together with a joining element. Therefore grab the joining element at the grab rail and insert it top down in the middle of the side rail elements until it snaps in audibly. To remove the joining element, hold it with one hand at the grab rail on top of the side rail and loose the locking mechanism of the joining element by pressing the movable grab rail. When it is unlocked lift the joining element carefully up.

The continuous siderails

Every care bed has two integrated siderails on each side at a height that is designed to guarantee safety. The siderails can be raised and lowered by a steel bar. The parts that move are particularly quiet as an impact damper has been built in, and the ends have an ornamental cap. With an ergonomically formed release button the siderails can easily be raised or lowered.

Usage of the continuous siderails

The release button to unlock the continuous side rails can be found on top of the upper side rails at the inside of head and foot section directly beneath the metal guides for the side lattices.

If the side rails are to be lowered, hold them by the designated groove of the upper siderail (fig. 1), lift this siderail firmly up and press the release button either on the head or on the foot section (fig. 2). The siderail is now released on that side and can be lowered downwards up to the impact. Now the siderail is in an diagonal position.

In order to lower the other side, you'll have to perform the steps described above on that side, too. The side rail is now in the lowered position.

If the side rails are to be raised as prevention from falling out of the bed, grab the upper side rail at center and lift it up, until it snaps audibly into its locked position on both ends. The side rail is now in the raised position.

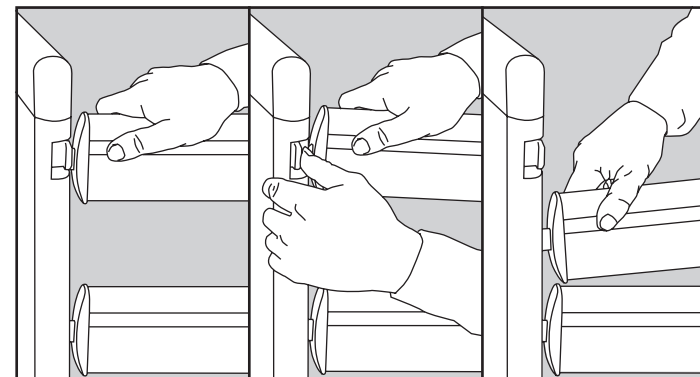

left: Fig. 1, center: fig. 2, right: fig.3



If you want the siderails back in the upper position as a protection from falling out of the bed, get the upper siderail in the center of the grasp-groove and pull it upwards, until it locks at both ends audibly.

The siderails are primarily intended to stop occupants falling out of bed.

They may not be sufficient for fragile patients so additional protective measures have to be taken, for example by adding relocatable siderail bumpers (an accessory).

The bars that make up the side rail must be at most 12 cm apart. When the siderails are used they must not remain in a diagonal position.

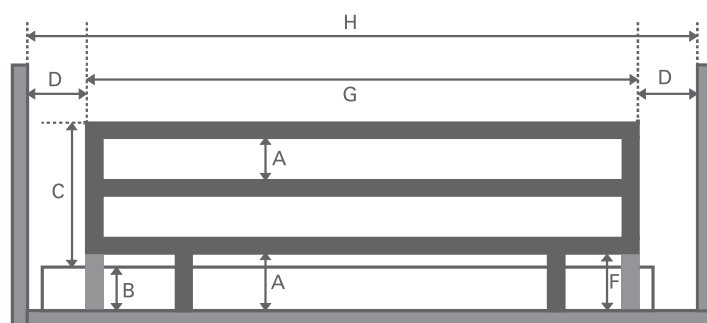

Dimensions of a continuous siderail

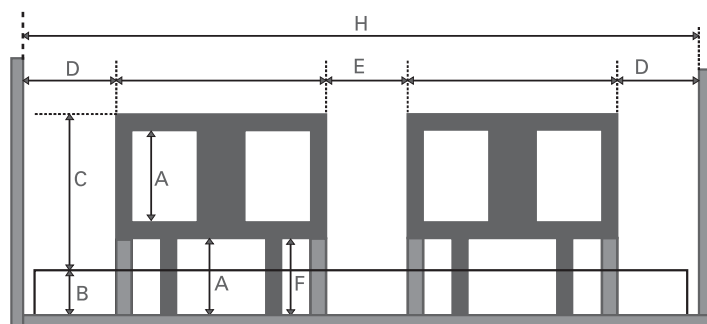

Dimensions of a split siderail

> Tip from Bock

There must be a minimum height of 22 cm without compression when different mattress thicknesses are in use. This is measured from the top edge of the side rail above the mattress. When higher mattresses are used, a side rail attachment that is available as an accessory has to be installed.

Various care beds from Bock have special functions that you can find in the assembly instructions for the individual models from chapter 7 on.

Note:

When the struts/fixing points of the siderails are outside (shown in light blue), then distance A to the lying surface is required beneath the siderails.

Letter	Dimensions	Requirements in mm
A	The shortest distance between elements of the side rail in its upright/locked position or the area that is formed by the side rail and fixed parts of the bed.	$A \leq 120$
B	Thickness of the mattress for proper usage.	See maker's specifications
C	Height of the top edge of the side rail above the mattress without compression (see "B").	$C \geq 220$
D	Distance between the head or foot section and the side rail.	$D \leq 60$ or $D \geq 235$
E	Distance between split side rails and the lying surface in a flat position.	$E \leq 60$ or $E \geq 235$
F	Smallest size of all accessible apertures between the side rails and the lying surface.	if $D \geq 235$ then $F \leq 60$ if $D \leq 60$ then $F \leq 120$
G	Total length of the side rails or the total lengths of split side rails on one side of the bed	$G \geq 1/2$ on the lying surface
H	Distance between the head and foot section without extensions to these parts	No requirements

Extract from the TÜV PS 51036 test program, dimensions of the siderail according to EN 60601-2-38

*** Warning note from Bock**

- Only use original Bock siderails that are available as accessories for all our care beds.
- Only use technically perfect, undamaged side rails with the permissible gaps.
- Make sure that the side rails slot into place securely.
- Before attaching the side rails and before every movement of the bed, check all mechanical parts of the bedstead and siderails that are used to fasten the siderails to make sure they are not damaged.
- The operation of the side rail should always be carried out with utmost care, since fingers can easily be squashed between the longitudinal bars.

> Tip from Bock

In the event of uncertain malfunction, failure or damage of the electric bed or its accessories, the first thing you should do is to remove the mains plug and activate the emergency lowering appliance. Please inform the operator or the Bock service team about the problem.

* Warning note from Bock

The operator has a duty to decide to undertake special safety measures for very agitated individuals in care, in order to prevent trapping of any limb or a person completely falling out. The Bock service team is happy to advise you on special solutions for these care situations.

3.3 Caution: Risk of injury

Proper use of all movable parts is essential to guarantee the safety of occupants, carers and nursing staff. The correct assembly and operation of the bed are essential for this. The physical constitution of the specific individual and the type and extent of disability must be taken into account when using the bed.

Use a control box to avoid hazards resulting from unintentional motor adjustments and incorrect handling. When the user, for example a nurse or caring relative, leaves the room, the functions of the hand control should be disabled completely by using the hand control key or disabled by using the separate control box. Then the lying surface has to be brought to its lowest position and activated the disabler with an appropriate turn of the key in the keylock located on the back.. Withdraw the key and as a precaution check that the hand control functions are actually disabled. Turn the knob switch when using a control box. These recommendations apply especially

- > When the occupant is unable to use the hand control properly because of certain disabilities
- > When the occupant could be put in danger as a result of unwanted adjustments
- > When the siderails are in a raised position and there is risk of trapping or injuring the occupant
- > When children are in the room containing the bed without supervision

When the hand control is not in use, make sure it is hung on the hook on the bed and cannot fall off.

The bed should only ever be operated by nursing staff or relatives who have received training, or in the presence of such persons.

When adjusting the lying surface, make sure that no limbs protrude into the siderails in the area that is being adjusted. When the siderails themselves are adjusted, it is essential to make sure that the occupant is in the right position, too.

Before starting an electrical adjustment always check whether any limbs are present in the adjustment area between lower chassis and back or lower leg section or even any child or person between the floor and raised lying surface. There is a particular high risk of injuring here.



Motor housing

4. Electric components

4.1 Drive unit

The drive unit consists of the motor box in which there are two motors for the individual drives to adjust the electrically operated parts of the back and leg supports. The integrated motor box incorporates a transformer and a rectifier in which the input voltage of 230 V at 50 - 60 Hz at 150 W is converted to low voltage of 24 V DC. The motors and the hand control operate with this non-dangerous low voltage. The cables are doubly insulated, and the mains plug has a primary fuse in accordance with EN 60601-1. An additional mains isolation appliance is coupled to actuation of the hand control. Emergency lowering of the bed is driven via a 9 V monobloc battery. Furthermore, voltage selection ensures the constant speed of functions. Safety features thus conform with protection class II and, for protection against moisture, IPX4 according to EN 60529.

* Warning note from Bock

The maximum period of operation of 2 minutes must not be exceeded. Afterwards it is essential to leave it unused for at least 18 minutes.



9-volt battery for emergency lowering

> Tip from Bock

When isolated from the mains, the bed is completely free of electromagnetic radiation. Electricity is only consumed when adjustments are carried out.

* Warning note from Bock

Although all Bock care beds are made to a very high safety standard this does not mean that there are no risks. Only when the manufacturer's specifications are heeded and the beds are used properly do the safety measures fulfil their actual purpose – acting on a preventive basis and actively avoiding risk.

If the maximum adjustment time of two minutes is exceeded, for instance through fiddling with the hand control, and if the motors overheat, the thermal release will immediately disconnect the power supply from the bed. Power will automatically be restored after a cooling-down time of about one hour. Since this drive does not operate at a frequency rate > 9 kHz and is mainly run for short periods, the guideline EN 550014-1 applies according to EN 60601-1-2 36.201.1.4.

4.2 Control box for all functions

The series hand control with six keys is fitted with an integrated disabling function which enables carers to lock the hand control completely. The easy disabling function in the hand control can therefore replace the current control box, when it is necessary to cut off the entire function of the bed.

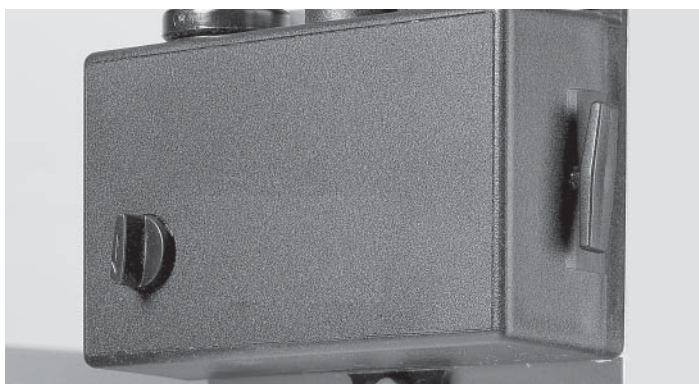

Control box

4.3 Height adjustment drive unit

The level of the lifting chassis can be adjusted via one or two built-in low voltage DC motors whose adjustment range is defined by an integrated limit switch. The height adjustment drive unit is connected by a coiled cable to the control unit.

4.4 Lockable hand control, single fault safety

Basic functions can be controlled by the press of a button on the ergonomic hand control using the six extra-large, user-friendly operating buttons.

The individual buttons are labelled to indicate their function. The motors run while a button is held down.

A coiled cable allows the necessary freedom of movement for operating.

The hook on the back can be turned 90° in both directions. The radius corresponds exactly to the radius of the side rail and support so that the handset fits securely. Special attention should be paid that during cleaning, disturbance by the hand control position be averted by turning it or clipping it to one of the appropriate places on the bed. The hand control also has an integrated disabler that can be activated or deactivated by its key.

To disable the entire electrical function, insert the key into the lock located on the rear and activate or deactivate the disabling function with a corresponding twist of the key.



The Bock hand control

- | | |
|----------|------------------------|
| Button 1 | Back section up |
| Button 2 | Back section down |
| Button 3 | Lower leg section up |
| Button 4 | Lower leg section down |
| Button 5 | Lying surface up |
| Button 6 | Lying surface down |

> Tip from Bock

Switch settings I and II operate the testing of individual switches and should only be used by authorised qualified personnel in the framework of the annual safety controls.

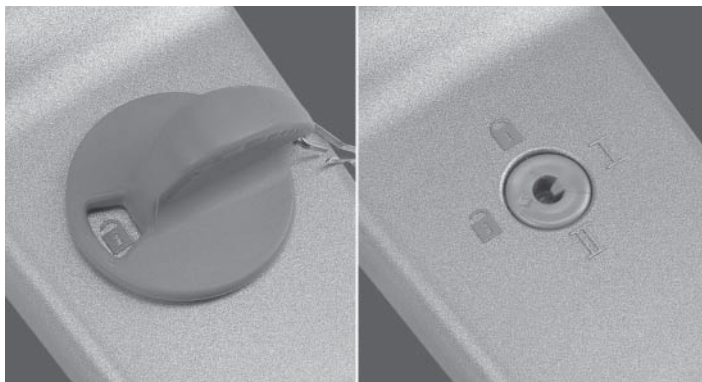
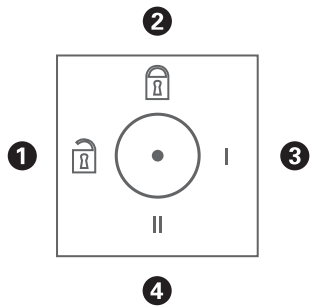

Key for disabler

Knob position 1 Hand control functions active
 Knob position 2 Hand control functions deactivated

Knob positions 3 and 4 are settings for safety controls. Further information on this can be found in the safety guidelines.

4.5 Caution: Electrical drive unit

Hermann Bock refers to its electrically operated therapy and rehabilitation beds as health beds because they have many functions that help their occupants to recover physically and psychologically while reducing pain. As medical devices, electric beds require special safety precautions including handling in a suitable way for safety, daily checks of electric equipment and proper maintenance and cleaning.

To avoid damage, cables should be laid outside the area in which damage can occur. Contact with edged parts should also be avoided.

Hints on adequate cable laying are given in chapter 7.7.

Excessive touch voltage should be avoided in order to prevent injury through electric shocks. These circumstances may arise, in particular, when the mains cable has been damaged, when there is inadmissible, excessive leakage current, or when liquid has penetrated the motor housing, for example because of incorrect cleaning.

Such damage can cause the controls to malfunction, resulting in unwanted movements of the individual bed elements that increase the risk of injury for nursing staff and users.

* Warning note from Bock

Simultaneous use of electrical equipment can, particularly in the immediate environment of the bed when it is ready to operate, result in small electromagnetic interactions between the electrical devices, similar to the interfering noise heard on the radio. In such a rare cases, increase the distance between the devices, do not use the same wall socket, or temporarily switch off either the interfering device or the one being interfered with.

If the bed, contrary to its intended use, is operated in combination with electrical and medical devices, the function of the bed must first be deactivated by means of the integrated locking function in the hand switch for the duration of use.

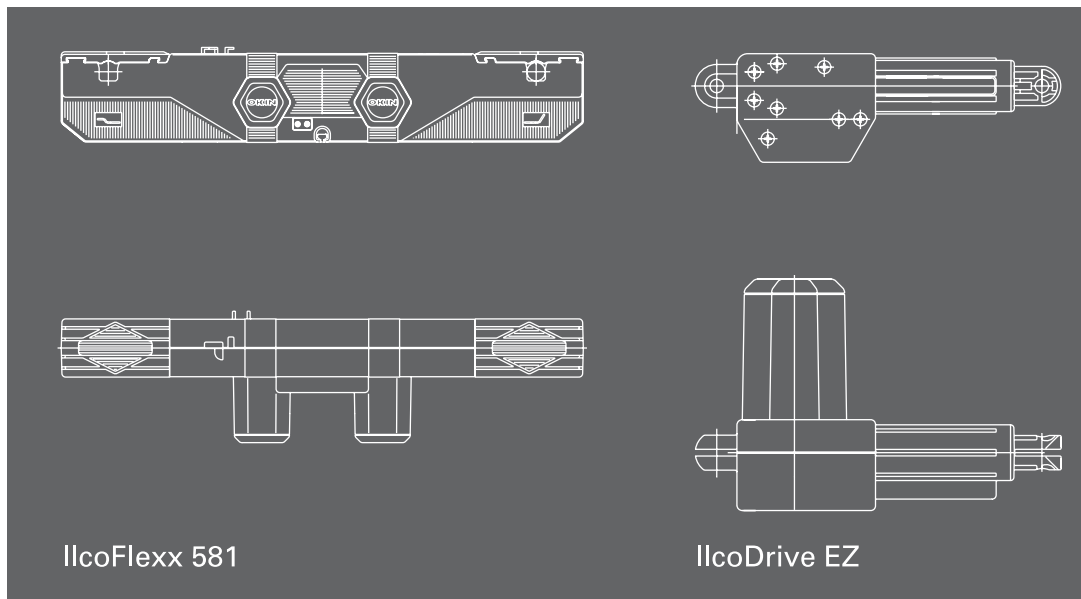

5. Drive units

Hermann Bock equips all health beds with ILCON drive systems. ILCON is a leading maker of adjustment systems with the necessary skills and expertise. This gives rise to an ideal partnership for medical devices with a unique level of quality thanks to this synergy.

5.1 IlcoFlexx 581 drive systems

The IlcoFlexx 581 dual drive unit for continuous adjustment of lying surfaces and the linear IlcoDrive EZ as a single drive unit to adjust the height of the lifting chassis each consist of four main components.

- Housing
- Motor
- Gearing
- Spindle with nut

The principle of the housing for the IlcoFlexx 581 dual drive unit and linear IlcoDrive EZ guarantee that all components will continue to function for a long time. The special design principle is based on two force-absorbing capsules. The patented, detailed interior design of the housing ensures that the drive technology will sit accurately.

* Warning note from Bock

No drive unit components are allowed to be opened! Only specially authorised technicians are allowed to carry out troubleshooting activities and replace individual electric components.

Assembly and disassembly instructions for electrical technicians are given in the "Upgrading with Bock" brochure, in part II – Instructions for electricians.

> Tip from Bock

The 9-volt batteries in the control should be tested once a year to see that they are functioning correctly, and be replaced if necessary. In addition visual inspections should be regularly carried out.



9-volt battery for emergency lowering

Ready-made, complete assemblies are not used. IlcoFlexx 581 housings are characterised by particularly easy assembly/disassembly and convenient space for the battery and electronic parts beneath the robust cover. The IlcoFlexx 581 can also be combined with all ILCON controls as an additional drive unit. The IlcoFlexx 581 has an isolation appliance in the mains plug and features emergency lowering. The noise level of ILCON drive units can exceed 65 dB(A).

5.2 Mains isolation

The ILCON mains isolation facility that is integrated in the mains plug provides other practical advantages in addition to guaranteeing a high level of safety. Activation of mains isolation prevents magnetic and electric alternating fields from being generated in the bed. The mains isolation facility operates independently and does not require an additional transformer for its standby mode. When the drive unit has been disconnected from the mains, no electricity is used and a switching noise in the relay indicates correct operation. Of course, mains isolation is compatible with higher-level mains isolation options.

The ILCON isolation facility in the mains plug is activated by pressing a button on the hand control. A capacitor charged with direct current in the drive unit supplies electricity to the two-pole relay in the mains isolation facility, and turns on the transformer in the drive. The capacitor is recharged, and is ready for the next actuation. Whenever the button on the hand control is released, the relay in the mains isolation facility turns off the mains network (two poles). A switching noise indicates that this function is being executed. The 9-volt battery that is installed in the control as standard for emergency movements will, if necessary, back up the mains isolation capacitor if the latter has not been used for some time and has therefore lost its voltage. If the capacitor and the 9-volt battery have been exhausted, it is sufficient to press the green button to get the mains isolation facility working again. When taking the bed out of service, the contact to the 9 Volt battery should be released by pulling out the plug.



Mains isolation closed and open

6. Accessories

Hermann Bock GmbH offers practical accessories that promote mobility to ensure that every care bed can be tailored to the specific requirements of its occupants. The accessories are attached easily and securely to the fixing points on the bed. Of course, every element of these accessories complies with Bock's special quality and safety standards. Beds can be extended to a length of 220 cm so that tall persons, too, can lie comfortably in them and enjoy the same level of functionality. Alongside our standard accessories for every bed we have an extensive range of extra accessories. These extras vary depending on the bed model, and are adjusted to the bed's special functions and place of use. These extra accessories range from technical elements through mattresses to a companion bed. A wide choice of wooden designs and colour variants is available so every care bed can be integrated harmoniously in existing surroundings.

6.1 Special sizes

At Hermann Bock GmbH, special sizes are standard models in our production processes.

Occupants with a particular physical build can only lie with optimum comfort if the beds have been specially made for them. With our special sizes, Hermann Bock enables every care bed to be tailored specifically to the occupant's physical condition. For persons taller than 190 cm Bock recommends using a bed extension that lengthens the lying surface up to 220 cm. In this way tall persons can lie in comfort and have the same level of functionality. Other special sizes and special functions are available in Bock's range of special beds as described in the "Bock Works In Special Ways" brochure.

* Warning note from Bock

For reasons of safety, only use original accessories from Bock that have been released for the bed model in question. A precise overview of accessories and extras for your bed is given in a separate data sheet. Hermann Bock GmbH will assume no liability for any accidents, damage, injury and risks that come about through the use of other accessories.

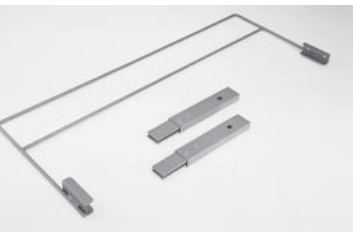

> Tip from Bock

Of course, the Bock service team will also assemble bed extensions if required. Bock always recommends that mattresses and bedding should be made of fire-retardant material in accordance with DIN EN 597.



6.2. Assembling bed extensions

A bed extension includes the following parts:

- 2 adapters for the left and right foot sections
- 1 wire brace for the foot section
- 1 set of siderails
- Screws

Easy assembly with a clip system is as follows:

1. Remove the mattress from the lying surface.
2. Remove the end piece from the foot section.
3. Attach the adapters to the foot end of the lying surface and screw them on.
4. Place the wire brace on the foot unit, drill holes (diameter = 4.2 mm), and screw the parts together.
5. Slide the end piece of the foot section directly in front of the release button.
6. TAKE NOTE of the markings above and below the end caps of the siderails as it is essential that they must not be confused.
7. Insert the siderails in the pre-assembled metal guides and centre it.
8. Push the release button inwards and slide in the foot section until it clicks into its borehole provided.

6.3 Assembling accessories

The following standard accessories can be combined with every Bock bed model:

Attachable siderails, 3.8 kg (Fig. 1)

Package: 2 siderails screws

- Loosen the screws on the side rail, insert the side rail, position it in the middle and tighten the screws.

Lifting pole with grab handle, 6.5 kg (Fig. 2)

The safe load limit of the lifting pole is 75 kg max.

Package: 1 lifting pole with mounting ring, 1 grab handle

- Insert the lifting pole in the headboard receptacle and arrest it, attach the grab handle to the mounting ring.
- The height setting of the triangle should be at a distance of no less than 550 mm to \geq 700 mm from the upper edge of the respective mattress (mattress height of 100 mm and 120 mm) to the lower edge of the horizontal grip.

Side rail bumpers, 1.4 kg (Fig. 3)

Package: 1 cover, 1 item of bumpers

- Open the zipper of the cover, pull the bumpers on to the side rail from above.
- Pull the foam bumpers from the inside of the bed into the cover, and close the zipper.

Grab rail, 3.0 kg

Package: 1 grab rail with holder

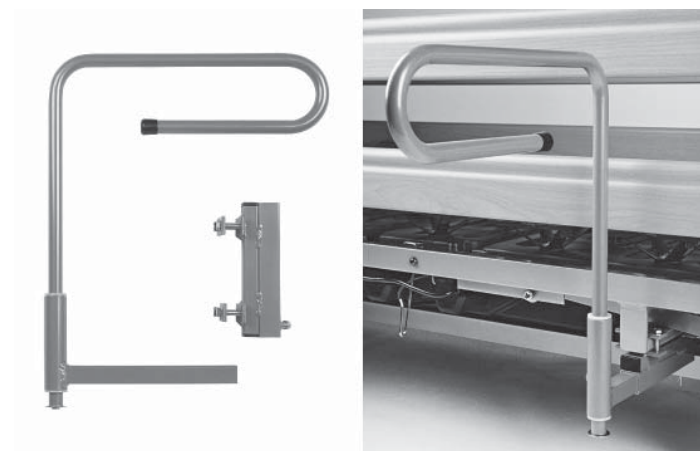

> Tip from Bock

The Bock service hotline will be pleased to advise you about the optimum upgrade option for your bed.

Please phone
+49 (0)180.5262500

An extensive range of additional furniture is available to supplement the various Bock bed models. The products available extend to the entire furnishing of rooms, thus combining care and convenience of living in a special way.



Fig. 1



Fig. 2



Fig. 3

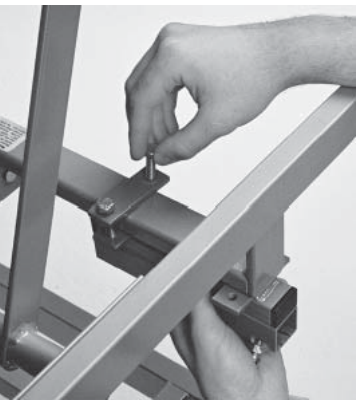

- Undo the four screws on the holder.
- Place the metal parts of the holder on the cross-member and screw them tight.
- Push the grab rail into the holder, position it as required and screw it tight.

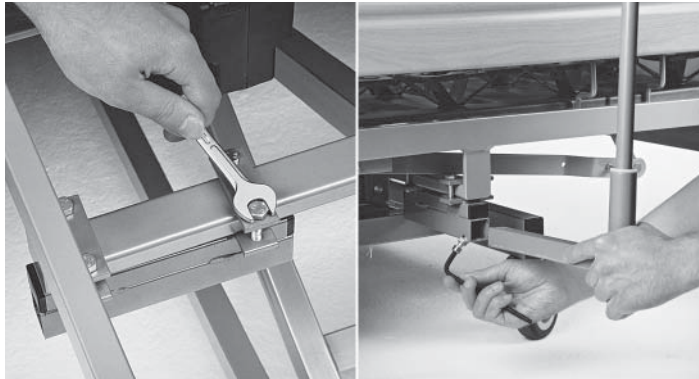

Fig. 4

Tray, 4.0 kg (Fig. 4)

Package: 1 bed tray

- Place the bed tray on the side rail. The tray is prevented from slipping by two spacers.

Urine bottle/bag holder, 1.2 kg

Package: 1 C-profile, 1 urine bottle/bag holder, screws

- Hold the C-profile in the middle beneath the longitudinal tube of the lying surface, mark the position of a hole, drill holes with a dia meter of 4.2 mm, and fasten with the screws that are in the package.
- Make sure that one end of the C-profile rail is directly touching the foot section cross-connection.



Goose-neck all-purpose clamp (0.6 kg)

Package: 1 clamp, 1 goose-neck, 1 fastening ring

The all-purpose clamp is a special holder that enhances its manoeuvrability as a basic component and enables the flexible positioning of the modular functional accessory. It is possible to fasten bags, urine bottle holders, infusion systems or a lamp, individually or at the same time. The goose-neck all-purpose clamp can also be attached onto the side rail exactly as required.

- The goose-neck is clamped onto the upper side rail and attached to the fastening ring.

6.4 Mattresses

Basically all foam and latex mattresses that have, at least, a volume weight of 35 kg per cubic meter and do not exceed a height of 10 to 12 cm for the dimensions of 90 x 190 cm, 100 x 190 cm, 90 x 200 cm and 100 x 200 cm can be used for Bock health beds. When higher mattresses are used, a side rail attachment that is available as an accessory has to be installed. When foam mattresses are used, we recommend making nicks in them so that they can be adjusted better to the lying surface.

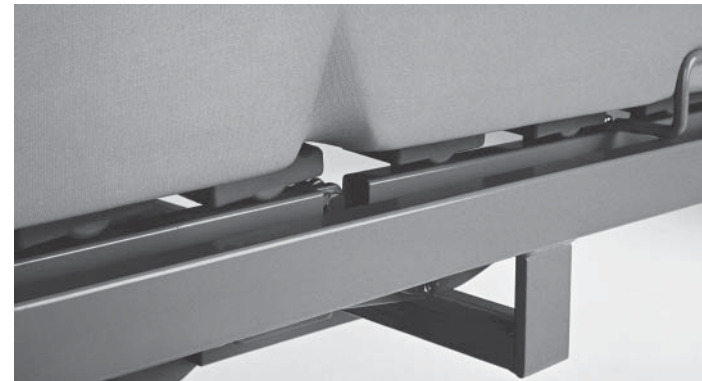

*** Warning note from Bock**

When using accessories on the bed or medical devices such as infusion stands in the direct vicinity of the bed, make sure that adjustment of the back and leg supports does not subject nursing staff to the risk of squashing/shearing.

> Tip from Bock

The Bock service hotline will be pleased to advise you about the optimum mattress for our ripolux support system. Please phone +49 (0)180.5262500

6.5 Special mattress ripocare

ripolux system-mattress for nearly pressure-free lying. The system-principles of Bock combines the intelligent lying-surface ripolux with the specially developed care-mattress ripocare to a lying-system, which perfectly absorbs any pressure. The combination of PU- and cold foam in a sandwich configuration enables a high point elasticity and body-adaptiveness. With that, the 10 cm high ripocare system-mattress ideally amplifies the functions of ripolux. Special cut-outs ensure, next to the essential flexibility of the lying surface, excellent climatic properties. The special mattress is available in dimension 90 x 200 cm, special sizes on request.

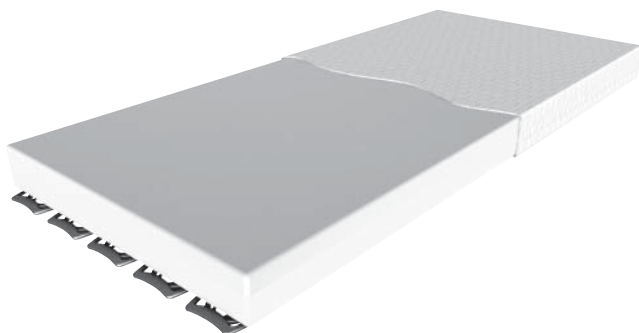

7. Setting up and operating – livorno

7.1 Design and purpose

The livorno was especially conceived for the demands of daily long-term use in home care. It gives the occupants, fragile and disabled people, the possibility of being supported in their usual environment with optimal care.

- > The livorno is not suitable for deployment in hospitals.
- > The livorno is suitable for transport of patients. The bed can move whilst occupied by a patient. To do this first lock the castors, lower the lying area to its lowest setting, and set horizontally. Unlock the castors and move the bed.
- > The livorno is suitable for occupants who are at least 12 years old and 150 cm tall.

Bock specifications

> livorno

Total weight:
109 kg

Lying surface area:
90 x 200 cm

External dimensions:
105 x 212 cm
(continuous side rails)
98,5 x 212 cm
(splitted side rails)

Safe capacity:
170 kg

Max. person weight:
135 kg

Height adjustment range:
37 - 83 cm

Max. angle to horizontal:
Back section 70°
Lower leg section 20°

Hoist clearance:
15 cm

Noise level:
< 65 dB(A)

- > The livorno can in some circumstances (when required) be applied for medical purposes together with other electro-medical devices (e.g. extraction equipment, ultrasonic atomisers, feeding systems, anti-bedsore systems, oxygen concentrators etc.). In such cases, all the bed's functions must be deactivated by means of the integrated locking facility for the duration of use of the other equipment.

Attention: The bed does not have any special connection provision for equipotential bonding. Medical electrical equipment connected intravascularly or intracardially to the patient shall not be used. The operator of the medical products is responsible for ensuring that the combination of devices satisfies the requirements of DIN EN60601-1-1.

7.2 Special features

livorno relies on long-established technology and can be particularly well integrated into existing residential environments thanks to its range of design elements.

The Lying surface is available articulated into 4 or 5 sections as an option. The electrical operation of back and leg sections is operated by the hand control for the lying surface; the leg section is fitted with an automatic 3 position adjustment.

7.3 livorno in parts

The following parts belong to livorno care beds:

Lying surface with box-type motor	1 item
Scissors-action chassis	1 item
Wooden side rail	4 items
Side panels	2 items
Head/foot section	2 items

Weights of separable livorno parts:

Subframe	14 kg/item
Action structure	21 kg/item
Wooden head/foot section	10 kg/item
Lying surface	42 kg/item
Siderail	12 kg/set

7.4 The livorno ready for use

Assembling livorno with continuous side rails:

Before you proceed with assembly, fully remove the remaining packaging.

1. Remove the bindings from the transport packaging.
2. Place the scissors-action chassis in an accessible position and brake the castors.
3. Remove both lying surfaces from the transport holder, fix them together. fasten them on both sides with the screws removed earlier using the allen key provided. Slot the motor on and slide on the caps.

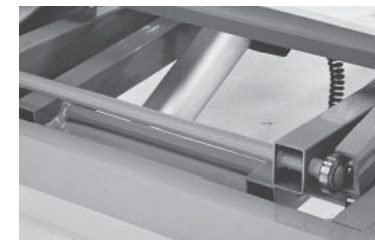

4. The ball-bearings in the upper part of the scissors structure have to be inserted in the U-profile at the lower end of the lying surface. Remove the spring clip on the chassis.



5. Arrest the lying surface between the two links using the previously removed key bolt. Use the spring clip to make sure the key bolts will not become detached unintentionally.





6. The mains cable must be screwed to the link of the lying surface using the strain relief. Connect the mains plug.
7. Raise the lying surface and insert the countersunk nuts in their holes.
8. Assemble the side panels (if present) to the longitudinal frames using the screws provided, in such a way that the roundings are facing down.
9. Insert a bed end with the screwed-on receptacle tubes into the flat steel at the head end as far as it will go, and screw it tight.
10. Place the four side rails on the receptacles on the bed end and leave it down gently on the lying surface behind the mattress fastener.
11. Push the second bed end gently into the lying surface at the foot end. Then push the bed end up to the stop and screw it tight. At the same time take the side rails (present on the lying surface) and push them in the appropriate receptacles and push the bed end in such a way that there is a distance of approx. 2 cm between bed end and side rail spar. Finally screw the end piece in tightly.
12. The mains cable must be screwed to the link of the lying surface using the strain relief. Connect the mains plug.
13. After assembling the bed and before putting it into service use the control to move the whole lying surface's adjustment range in order to test optimum positioning of the cabling. It must be possible to cross the entire adjustment range without obstruction. The mains cable must run outside the bed, and the hand control must be readily accessible.

Your livorno with continuous siderails is now ready for use!

Assembling livorno with splitted side rails:

Before you proceed with assembly, fully remove the remaining packaging.

1. Remove the bindings from the transport packaging.
2. Place the scissors-action chassis in an accessible position and brake the castors.
3. Remove both lying surfaces from the transport holder, fix them together. fasten them on both sides with the screws removed earlier using the allen key provided. Slot the motor on and slide on the caps.
4. The ball-bearings in the upper part of the scissors structure have to be inserted in the U-profile at the lower end of the lying surface. Remove the spring clip on the chassis.
5. Arrest the lying surface between the two links using the previously removed key bolt. Use the spring clip to make sure the key bolts will not become detached unintentionally.
6. The mains cable must be screwed to the link of the lying surface using the strain relief. Connect the mains plug.
7. Raise the lying surface and insert the countersunk nuts in their holes.
8. Assemble the side panels (if present) to the longitudinal frames using the screws provided, in such a way that the roundings are facing down.
9. Insert a bed end with the screwed-on receptacle tubes into the flat steel at the head end as far as it will go, and screw it tight.
10. Take one splitted side rail and insert it completely into the designated holes of the lying surface frame. Fasten it with the provided screws and take care the side rails are mounted on the right place. Assemble the other side rails one after another in the same way.

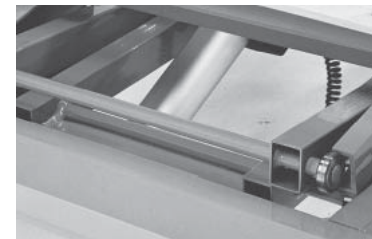

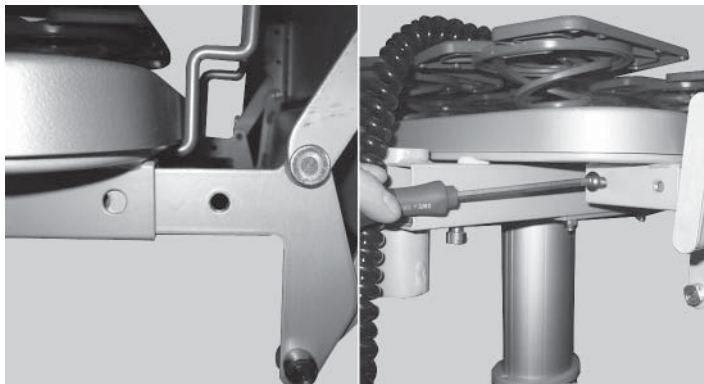
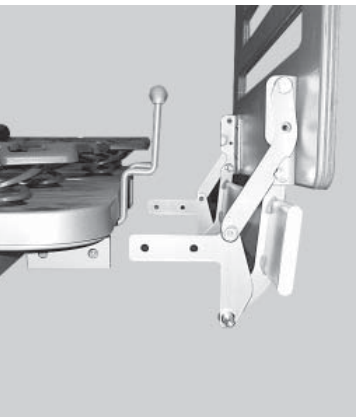

*** Warning note from Bock**

When lowering the lying surface there is an increased risk of squashing in the area between the four integrated castors and under the lower chassis cover.

Always check before making an electrical adjustment whether single limbs (hands, fingers) are present between the upper edge of the wooden cladding of the scissors and the lying surface in the leg section area, since with the livorno the danger of squashing or slicing is high in that area.

11. The mains cable must be screwed to the link of the lying surface using the strain relief. Connect the mains plug.
12. After assembling the bed and before putting it into service use the control to move the whole lying surface's adjustment range in order to test optimum positioning of the cabling. It must be possible to cross the entire adjustment range without obstruction. The mains cable must run outside the bed, and the hand control must be readily accessible.

Your livorno with splitted siderails is now ready for use!

7.5 Control

The hand control is used to control the settings. The following functions can be controlled by pressing the appropriate button on the hand control:



The Bock hand control

- | | |
|----------|------------------------|
| Button 1 | Back section up |
| Button 2 | Back section down |
| Button 3 | Lower leg section up |
| Button 4 | Lower leg section down |
| Button 5 | Lying surface up |
| Button 6 | Lying surface down |

The hand control also has an integrated disabler that can be activated or deactivated by its key. To disable the entire electrical function, insert the key into the lock located on the rear and activate or deactivate the disabling function with a corresponding twist of the key.

- | | |
|-----------------|------------------------------------|
| Knob position 1 | Hand control functions active |
| Knob position 2 | Hand control functions deactivated |

Knob positions 3 and 4 are settings for safety controls. Further information on this can be found in the safety guidelines.

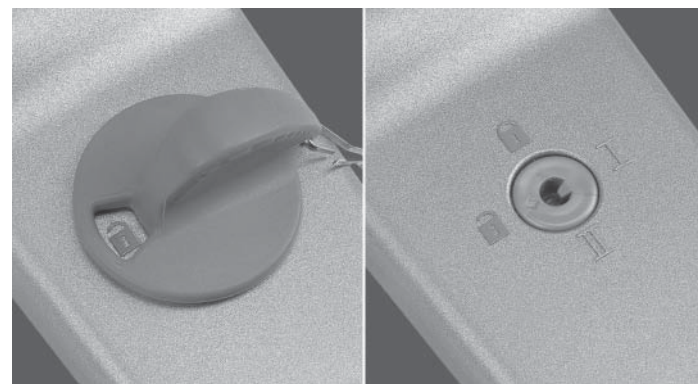
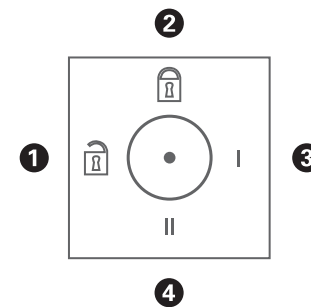

Key for disabler

7.6 Disassembly

Before starting disassembly pull out the mains plug. The livorno is disassembled in the opposite order to assembly.

* Warning note from Bock

The motors comply with the IPX4 splashwater protection level. The cables must not be squashed. Movable parts must only be adjusted in keeping with the rules for proper usage. Hermann Bock GmbH will not assume any liability for unapproved technical modifications.

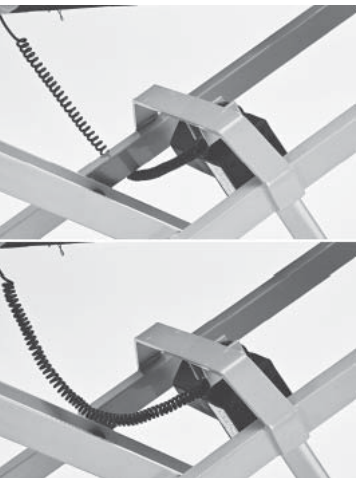

Cable guidance:
above wrong, below correct

7.7 Relocation

Note the following safety instructions if the bed has to be relocated:

- Place the lying surface in its lowest position.
- Before relocating the bed, remove the mains plug and fasten it to the wooden siderail with the suspension device to make sure that the mains cable does not fall down or cannot be run over. It is important that the cable does not drag over the floor.
- Pull plug out of the 9 volt battery. When reconnecting the bed fasten the plug onto the IlcoFlexx 581 again.
- Before reinserting the mains plug, visually check the mains cable for mechanical damage (bends, pressure points, abrasions and exposed wires).
- Lay the mains cable in such a way that, when the bed is in use, it cannot be pulled, run over or jeopardised by moving parts of the bed, and then reinsert the mains plug.
- Before relocating the bed, remove the mains plug and make sure that the mains cable cannot fall down and be run over.

7.8 Transport and storage conditions

- 0 °C to 40 °C
- Humidity 20% -80%
- air pressure between 700 and 1060 hPa

7.9 Functioning advice

This special function can be separately switched off by using the disabler for individual functions.

The brakes have to be locked onto the castors in order to fix the bed in one place. The foot lever on the breaking units on each castor has to be depressed downwards. livorno is optionally equipped with central-locking of all brakes. The parallel locking of all steering castors is enabled by a downward tread on the brake pedal. The brakes are all released in the middle setting, in the high setting a guiding castor is set in the straight-ahead position.

The integrated side rail has to be raised when necessary so that it slots in at both ends. To lower, raise the side rail slightly and press the release button at the outer edge gently.

The hardness of the lying surface can be adjusted continuously by means of a slide. A higher degree of hardness can be achieved by moving the slide outwards.

There must be a minimum height of 22 cm without compression when different mattress thickness are in use. This is measured from the top edge of the side rail above the mattress (a third side rail attachment is to be used).

7.10 Disposal

The individual plastic, metal and wood component materials are recyclable and can be recycled according to legal regulations.

*** Warning note from Bock**

Never try to fix problems relating to electric equipment yourself as this could endanger your life in certain circumstances!
 Either get the Bock customer service or authorised electrical technicians to solve the problem; they will comply with all key safety rules and regulations.

7.11 Troubleshooting

This overview indicates malfunctions that you can easily test and eliminate yourself, and what malfunctions have to be dealt with by experts.

Malfunction	Potential causes	Remedy
The drive units cannot be controlled via the hand control	Mains cable not connected No voltage in the socket Plug of the hand control not fixed firmly Hand control or drive unit defective Mains isolation appliance not activated Disabler or control box in the hand control activated	Connect the mains cable Check the socket or fuse box Check the plug-in connection on the motor Notify the operator or Bock customer service Press the green button to activate mains isolation, and also replace the 9 V battery Deactivate disabler or control box in the hand control
When buttons are pressed, the drive units stop after a short time	There is an obstruction in the adjustment range The safe capacity has been exceeded	Remove the obstruction Reduce the load
The drives stop after a longer adjustment time	The adjustment time or safe capacity has been exceeded, and the Polyswitch in the transformer of the control unit has responded to increased heat	Let the drive system cool down sufficiently for at least a minute
Opposite functions when the hand control is used	Motor plugs have been swapped round internally	Notify the operator or Bock customer service
Individual drive units run in one direction only	Hand control, drive unit or controller defective	Notify the operator or Bock customer service
Drives stop and bed remains in sloping position	Continuous operation of the up/down adjustment function or head/leg low position. Activate disabler in hand control.	Lower lying surface into its lowest position and thus realign horizontally.



> Tip from Bock

For Bock technical safety control seminars your technical staff will be trained for safety control qualification for Bock healthcare beds either at your location or in-house on our premises, and thus be in a position to carry out technical safety checks according to BVG A2 and the product operators regulations and the relevant regulatory body for medical products.

8. Safety guidelines

General safety test

The safety standards of an electrically driven care bed are regulated by adhering to the Euro Standards laid down.

Moreover the manufacturer is subject to the strict official regulations laid down at the German local government level that are contained in the safety recommendations of the BfArM (Federal Institute for Medical Products) for the implementation of legislation on medical products. The maintenance of the high security standards are ensured by continuous official safety bodies tests (TÜV).

Top Bock safety standard

At Hermann Bock the identification with safety and the protection of those in care beds goes beyond the fulfilment of all statutory guidelines and recommendations. Our own research and safety division develops additional preventative safety measures from accident investigations, market studies and practical experience. Thus Hermann Bock health beds have always been well above the legally required standard, the highest standard known as the Bock - Top - standard.

8.1 Safety guidelines for electrically operated bed systems

The following safety requirements according to the latest findings on accident and burn prevention have to be met by electrically operated care beds:

> Top Bock standard

Use of reinforced mains connections (EPR cable or cable of comparable quality)

> Top Bock standard

Sufficient prevention of buckling and adequate strain relief on connections between drive units and mains connectors (see Fig. 1).

> Top Bock standard

Mains connectors as well as electric cable connectors between the drive system components have to be arranged within the bed in such a way that mechanical damage is improbable (see Fig. 2).

> Top Bock standard

It must be ensured that the cable does not touch the floor when the bed is being moved (see Fig. 3).

> Top Bock standard

In the operating information there are instructions to be noted in order to avoid mechanical stress to the mains connection during use.

> Top Bock standard

A suitable notice in the operating instruction is required so that the mains connections are regularly at least checked visually with regard to mechanical damage, particularly after each occurrence of mechanical stress.

> Top Bock standard

Protecting drive against moisture. With older beds at the very least there have to be checks that fluid cannot drip downwards into the drive.

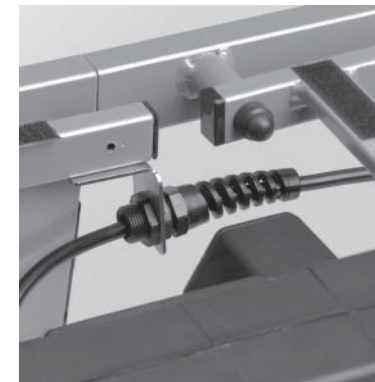

Fig. 1



Fig. 2



Fig. 3



Important safety requirements for care beds:

- > The complete drive system including hand control has to be protected from water splashing (in accordance with IPX4, see fig. 4).
- > Prevention of buckling, strain relief on bed and high quality mains cable.
- > The distances of the side rail sections must be ≤ 12 cm apart, even after being under strain and pressure.
- > All bed system drives are equipped with total mains isolation with an inbuilt safety device within the plug. This safety appliance in the plug responds to possible damage to the mains cable and cuts off the current directly in the mains socket. At the same time the emergency lowering of the lying surface ensures the safety of the occupant. A highgrade, resistant helix cable ensures against damage to the mains cable.

Fig. 4

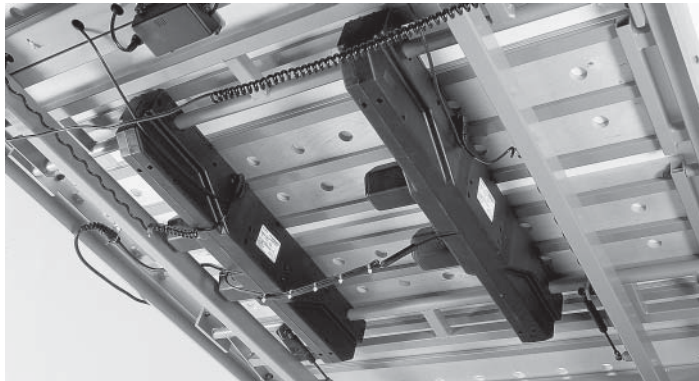

8.2 The "Top-Ten" safety guarantees.

Bock top guarantee 1: Mains isolation

The mains isolation enables current supply only when the hand control is in use. Otherwise the drive is cut off on all poles at the plug from the mains. The drive is then in the same state as if the plug had been pulled out.

Bock top guarantee 2: Primary fuse

The primary fuse functions as a second safety guarantee, and with Bock is located directly in the wall plug and not in the box-type motor. This location offers the great safety advantage in that the bed will be separated from the mains at the slightest functional irregularity and thus prevents possible dangers resulting from damage to the mains cable.

- > Safety advantage 1: In the event that the helix cable should nevertheless be damaged, the short-circuiting will only occur within the briefest moment after actuation of the hand control, and then only when the phase and neutral wire are connected. The primary fuse in the mains plug reacts immediately to damage to the mains cable and causes power to be cut off, the moment that the current rating has been exceeded.
- > Safety advantage 2: Despite mains isolation when the bed is put into operation there has to be a power supply. Should a control line be damaged in the mains cable, the motor will be disconnected from the mains automatically.



Bock top guarantee 3: Secondary fuse/Polyswitch

Should there be a short-circuit in the secondary circuit (24 V) the secondary fuse reacts immediately. The drive will be cut off from the mains immediately. Even with a possible shortcircuit or overload in the load circuit, the secondary fuse ensures that the drives are switched to zero voltage. After the required cooling-off period, the Polyswitch switches the drive on again.

* Warning note from Bock

Before reuse, the bed has to be cleaned and disinfected. A visual check must also be carried out to check for any mechanical damage.

Bock top guarantee 4: Thermal release

In the event that the electrical resistance with a short-circuit is not small enough, the mains isolation will not switch on again automatically. Since the drive would not operate or operate only very slowly, the adjustment times last correspondingly long. The hand control would be actuated for doing this for some time, and the drive would be constantly connected to the mains. The transformer would be under correspondingly great stress as a result. Should the resultant heat reach 130°C, the thermal release of the transformer would trip and separate the drive from the mains immediately. In that case the drive should be serviced by the manufacturer or the operator and a new transformer should be fitted.

Bock top guarantee 5: Disabler unit for all functions in the hand control

The lockable hand control which is fitted with an integrated disabler enables the user to disable the hand control by means of a key. To disable the entire electrical function, insert the key into the lock located on the rear and activate or deactivate the disabling function with a corresponding twist of the key. The central disabler unit in the hand control is available for all health beds with horizontal adjustment by motors.

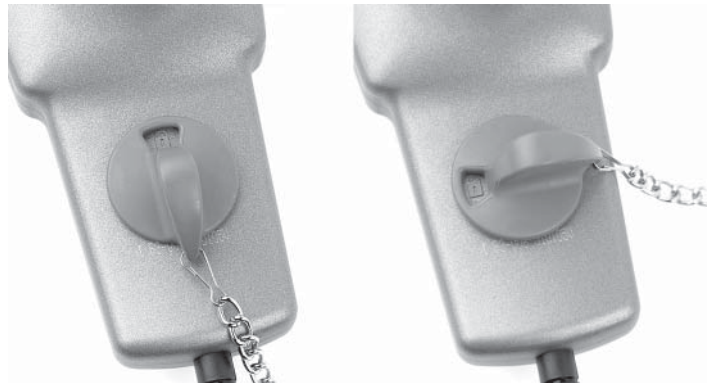

Bock top guarantee 6: Disabler unit for individual functions

For practical protection against injury, all Bock special beds and models with the special "Trendelenburg" function are provided with a disabler unit for individual functions in order to disable certain functions.



Bock top guarantee 7: Special helix mains cable

This special mains cable, due to the presence of the mains isolation, has four instead of the usual two wires. The insulation is considerably thicker than that of the usual mains cable. The round version is also in flex form and increases the stability of the cable considerably.

- > Safety advantage 1: Running over the cable with the castors of the bed is almost impossible, as it is hard to run over a flex cable and the castors tend to push the cable in front of them.
- > Safety advantage 2: The coil of the cable enables a considerable play in the length by which a pulling out of the cable is prevented.
- > Safety advantage 3: The coil or flex form withstands the constant pulling of the cable and it enables easy attachment during transport.



Bock top guarantee 8: Strain relief on mains cable and buckle protection

Pulling out of the cable is prevented by the strain relief of the mains cable directly on the drive housing. An additional strain relief on the bed is installed so that the cable leaves the chassis on its outer edge. Thus, by the correct laying of the cable from the bed to the plug, the cable does not come into contact with movable parts of the bed (see also fig. p. 2/3).



Bock top guarantee 9: Lockable hand control, single fault safety

The disabler in the lockable hand control is activated by two integrated switches. Should a switch function fail, a second switch ensures the reliable and secure functioning of the disabler. For the individual checking of the function of each switch in the context of safety controls, the disabler is equipped with two checking settings.

> Tip from Bock

The Bock service hotline will be pleased to advise you about the optimum upgrade option for your bed. Please phone +49 (0) 1805262500. Or fill in the upgrade checklist that you will find in the separate brochure "Upgrading with Bock". Bock will then automatically put your upgrade together. The BfArM and the regional authorities recommend the upgrade of electrically driven beds or disconnecting them from mains when not in use. Bock will advise you which beds cannot be upgraded because of cost reasons.

Bock top guarantee 10: Moisture protection

The drive housing meets the IPX4 protection level with its tongue and groove construction and is protected from splashing water by silicon sealings. In the improbable event that somehow some fluid does penetrate, contact is prevented by the adapted interior construction of the electrical components in the upper areas of the housing. The moisture flows automatically downwards and leaves the drive without causing damage to the electrical components.



8.3 Technical safety checks with service

Technical safety controls have the aim of keeping to the highest possible level of safety and are therefore an important safety provision. Technical medical appliances have to be safety-checked regularly according to the given intervals of the manufacturer and the generally recognised technical regulations. The technical safety preventive measures are subject to different requirements and demands in daily practice, therefore also the possible appearance of wear and tear. In order to prevent danger safely, it is essential to abide strictly by the intervals for the technical safety checks according to government safety organisations. The manufacturer thus has no influence on how far the rules laid down by the operator of the electric beds are being adhered to. Bock makes the adherence to the necessary safety provisions simple with time-saving service benefits.

The technical safety check may only be carried out by persons who, because of their education, knowledge and skills acquired through experience, have gained the reliability required for a correct execution of the safety check, is not bound by any instructions with regard to the inspection activity and has suitable measuring and testing equipment at his disposal.

In the event that no-one is suitable or no-one is selected from among the operator's staff, Bock Service offers you the possibility of taking over the safety checking and adherence to the corresponding maintenance intervals, for a charge. The operator also has a duty to carry out visual and functional tests according to basic guidelines at regular intervals and before each new occupancy of the bed. To carry out the test on their own, there is a checklist for these safety guidelines for operators, in which all details relevant to safety are contained.

Hermann Bock recommends an annual check as standard as well as a repeated one before and after each reuse of the bed. Please copy the checklist as a form for your test requalifications. The checklist is a valid maintenance protocol and should be kept after the technical safety control. The checklist can also be obtained as a download from the internet: www.bock.net

> Tip from Bock

For Bock technical safety control seminars your technical staff will be trained for safety control qualification for Bock health-care beds either at your location or in-house on our premises, and thus be in a position to carry out technical safety checks according to BVG A2 and the product operators regulations and the relevant regulatory body for medical products.

* Warning note from Bock

Before reuse, the bed has to be cleaned and disinfected. A visual check must also be carried out to check for any mechanical damage.

STK - List according VDE 0751-1



Test specimen: Bed Insert frame Controller/main drive

Model name: _____

Series /inventory number: _____

Location: _____

Person in charge: _____

Date, examiner: _____

Visual, mechanical and electrical step of examination

- | | | |
|-----|---|--|
| 1. | Is the overall condition of the bed alright? | <input type="checkbox"/> Yes <input type="checkbox"/> No |
| | Description of defects: | |
| 2. | All stickers, EC registrations and type plates present on bed? | <input type="checkbox"/> Yes <input type="checkbox"/> No |
| | Description of defects: | |
| 3. | Manufacturer's details such as safety guidelines and assembly or operating instructions present? | <input type="checkbox"/> Yes <input type="checkbox"/> No |
| | Description of defects: | |
| 4. | Mechanical construction defect free with no welds, bent metal frames/lifting poles, wooden elements? | <input type="checkbox"/> Yes <input type="checkbox"/> No |
| | Description of defects: | |
| 5. | Firm fit and completeness of all mechanical connecting elements (screws etc.)? | <input type="checkbox"/> Yes <input type="checkbox"/> No |
| | Description of defects: | |
| 6. | Sprung slats, carrier plates and dowels for ripolux/riplan without cracks or breakages? | <input type="checkbox"/> Yes <input type="checkbox"/> No |
| | Description of defects: | |
| 7. | Tight fit in correct position of all sprung slats and carrier plates? | <input type="checkbox"/> Yes <input type="checkbox"/> No |
| | Description of defects: | |
| 8. | Tight fit and straight alignment of all spring elements? | <input type="checkbox"/> Yes <input type="checkbox"/> No |
| | Description of defects: | |
| 9. | Do spring elements return to their original position after pressure load? | <input type="checkbox"/> Yes <input type="checkbox"/> No |
| | Description of defects: | |
| 10. | Tight fit and no cracks or breakages of head and foot end panels? | <input type="checkbox"/> Yes <input type="checkbox"/> No |
| | Description of defects: | |
| 11. | Adjusting space of lying surface and room for lifting height sufficient without obstructions at current location? | <input type="checkbox"/> Yes <input type="checkbox"/> No |
| | Description of defects: | |
| 12. | Safe grid mechanism of lower leg section in every step even under charge? | <input type="checkbox"/> Yes <input type="checkbox"/> No |
| | Description of defects: | |
| 13. | Side rail bars without cracks, breakages or damages? | <input type="checkbox"/> Yes <input type="checkbox"/> No |
| | Description of defects: | |
| 14. | Adequate fastening and respectively secure fit of side rails? | <input type="checkbox"/> Yes <input type="checkbox"/> No |
| | Description of defects: | |
| 15. | Load test of side rails without distortion? | <input type="checkbox"/> Yes <input type="checkbox"/> No |
| | Description of defects: | |
| 16. | Easy run of side rail bars within the tracks and easy locking? | <input type="checkbox"/> Yes <input type="checkbox"/> No |
| | Description of defects: | |
| 17. | Correct functions of side rails? | <input type="checkbox"/> Yes <input type="checkbox"/> No |
| | Description of defects: | |
| 18. | Distance between side rail bars not more than 12 cm? | <input type="checkbox"/> Yes <input type="checkbox"/> No |
| | Description of defects: | |
| 19. | Height of side rails above mattress at least 22 cm? | <input type="checkbox"/> Yes <input type="checkbox"/> No |
| | Description of defects: | |

- | | | |
|-----|---|---|
| 20. | Bed-accessories (lifting pole, triangle grab handle, belts, control box etc.) without damages and with secure fixing? | <input type="checkbox"/> Yes <input type="checkbox"/> No |
| | Description of defects: | |
| 21. | Safe breaks, arresting and free running of wheels? | <input type="checkbox"/> Yes <input type="checkbox"/> No |
| | Description of defects: | |
| 22. | Mains cable, connecting cables and plugs without scratches, dents, kinks, porous parts or bare wires? | <input type="checkbox"/> Yes <input type="checkbox"/> No |
| | Description of defects: | |
| 23. | Strain relief fastened and efficient? | <input type="checkbox"/> Yes <input type="checkbox"/> No |
| | Description of defects: | |
| 24. | Internal plugs fully inserted and connected with strain relief? | <input type="checkbox"/> Yes <input type="checkbox"/> No |
| | Description of defects: | |
| 25. | Mains cable and plug without damage? | <input type="checkbox"/> Yes <input type="checkbox"/> No |
| | Description of defects: | |
| 26. | Correct and secure cable leading and cable connections? | <input type="checkbox"/> Yes <input type="checkbox"/> No |
| | Description of defects: | |
| 27. | Housings of motors and hand controls sealed and without damages? | <input type="checkbox"/> Yes <input type="checkbox"/> No |
| | Description of defects: | |
| 28. | Leak-prevention of motor for models older than 2001 present? | <input type="checkbox"/> Yes <input type="checkbox"/> No |
| | Description of defects: | |
| 29. | Motor lifting poles without damages? | <input type="checkbox"/> Yes <input type="checkbox"/> No |
| | Description of defects: | |
| 30. | Testing of hand controls: all buttons fully usable? | <input type="checkbox"/> Yes <input type="checkbox"/> No |
| | Description of defects: | |
| 31. | Testing of disabler on hand control: everything correct? | <input type="checkbox"/> Yes <input type="checkbox"/> No |
| | Description of defects: | |
| 32. | Testing of battery: faultless function? | <input type="checkbox"/> Yes <input type="checkbox"/> No |
| | Description of defects: | |
| 33. | Resistance of protective conductor: not applicable, because no protective conductor present (security class II) | <input type="checkbox"/> Yes <input type="checkbox"/> No |
| | Description of defects: | |
| 34. | Resistance of isolator (for old appliances) (initiate proof voltage and measure resistance; measured value must be more than 7 MΩ): | |
| | Description of defects: | |
| 35. | Alternative leakage current, maximum value (device over 200 V, security class II, type B, threshold value = 0,1 mA): | <input type="checkbox"/> OK <input type="checkbox"/> Not OK |
| | Description of defects: | |
| 36. | Exceeds the patient-, mattress and accessory weight the assigned safe capacity (see technical data)? | <input type="checkbox"/> Yes <input type="checkbox"/> No |
| | Description of defects: | |

Overall condition of the bed: everything faultless? Yes No

Notices: _____

Place and date: _____
 Signature of examinant: _____
 Next examination: _____

Declaration of conformity

Manufacturer: Hermann Bock GmbH
Nickelstraße 12
D-33415 Verl

Product: care bed livorno

Classification: Medicine products class I, norm 1 and 12
appendix IX of the MDD

Selected conformity
appraisal procedure: Appendix VII of the MDD

Hereby we declare that the products specified above fulfil the precautions of the guideline 93/42/EWG of the advice over medicine products. The entire associated documentation is kept in the premises of the manufacturer.

Applied standards: Harmonised standards, for which the proof of agreement can be supplied:

DIN EN 14971 Application of risk management to medical devices

DIN EN 1970 Adjustable beds for disabled persons

DIN EN 60601-1 Medical electrical equipment Part 1

DIN EN 60601-1-2 Medical electrical equipment Part 1-2:
Electromagnetic compatibility

DIN EN 60601-2-38/A1 Medical electrical equipment Part 2-38:
Particular requirements for the safety of electrically operated hospital beds
(as relevant to home care)

Verl, February 12th 2009



Klaus Bock
(Management)



Jürgen Berenbrinker
(Management)

.bock[®] ///

Hermann Bock GmbH
Nickelstr. 12
33415 Verl
Germany

Phone: +49 (0) 52 46 92 05-0
Fax: +49 (0) 52 46 92 05-25
Internet: www.bock.net
E-Mail: info@bock.net